

Pole Bolt - Three Phase

THREE PHASE SMALL CAPACITY POLE BOLTED TRANSFORMERS

Product Data Sheet

Revision: 1

ETEL

ISO 9001 Registered

ETEL brings over 25 years of experience in Distribution Transformers together with state of the art manufacturing techniques to produce high quality, low loss three phase Pole Bolted Transformers.

The Small Capacity Pole Bolt Selection includes platform and pole bolted arrangements from 10kVA through to 75kVA (100 - 630kVA capacity available in larger housing) as utilised in Australia, New Zealand and the Pacific Islands.

ETEL offers as standard the best long-term finish, utilising fully Hot Dipped Galvanised Tanks and Lids. Painted and other solutions are available.



Features

- Integrated pole bolting arrangements
- Lid mounted HV bushings
- Long life hot dipped galvanized finish
- 10 to 75kVA (up to 630kVA available in larger housing)
- Lifting lugs
- Surge arrester brackets
- Optional fitted HV and LV surge arrestors
- Optional birdcap protection
- Optional pole bolt to crossarm adaptor bracket

Technical Specifications

Core Type	Distributed gap wound core, shell type transformers
Electrical Steel Type	Cold rolled, grain oriented, silicon steel sheets
Tank Sealing	Hermetically sealed
Oil Type	Oil filled to AS1767 and BS148
HV Volts	6600, 11000, 22000, 33000 (others available)
LV Volts	433 - 250V Dyn11 As standard (others available)
HV Tappings	+5% to -7.5% in 2.5% steps As standard (others available)
Oil / Winding Rises	60 / 65°C As standard (others available)
BIL / Power Frequency Levels	95kVpeak / 28kVrms 150kVpeak / 50kVrms 200kVpeak / 70kVrms
Maximum Operating Pressure	35kPA

Pole Bolt - Three Phase

THREE PHASE SMALL CAPACITY POLE BOLTED TRANSFORMERS

Product Data Sheet

Revision: 1



ISO 9001 Registered

ITEM	DESCRIPTION
1	HV BUSHING 22kV ESAA No77
2	LV BUSHING 0.66kV ESAA 200A
3	TAPSWITCH HANDLE & LOCKING BRACKET
4	RATING PLATE
5	POLE MOUNTING BRACKET
6	LIFTING LUG
7	EARTH FLAG C/W M12 S/S SET SCREW
8	SURGE ARRESTER BRACKET
9	SURGE ARRESTER 21kV, WITH BIRDCAP - (OPTIONAL)
10	BIRDCAP FOR HV BUSHINGS - (OPTIONAL)
11	100mm x 50mm WOODEN TRANSPORT FEET
12	BRACKET ADAPTOR POLEBOLT TO CROSSARM - (OPTIONAL)

kVA	OIL Litres	UNTANKING MASS kg	TOTAL kg	WIDTH DIM 'A'	DEPTH DIM 'B'	HEIGHT DIM 'C'	SEPARATION DIM 'E'	CENTRES DIM 'F'	CENTRES DIM 'G'
25	140	170	375	1030	700	1040	410	140	380
63	175	300	570	1050	720	1170	420	140	600

FOR TENDER PURPOSES ONLY
NOT FOR MANUFACTURE

- NOTES:
- 1 ETEL COMPANY LABEL (75mm LETTERING)
 - 2 kVA RATING (50mm LETTERING)
 - 3 ETEL SERIAL NUMBER (50mm LETTERING)
 - 4 LABELS - SELF ADHESIVE, BLACK VINYL, WEATHERPROOF

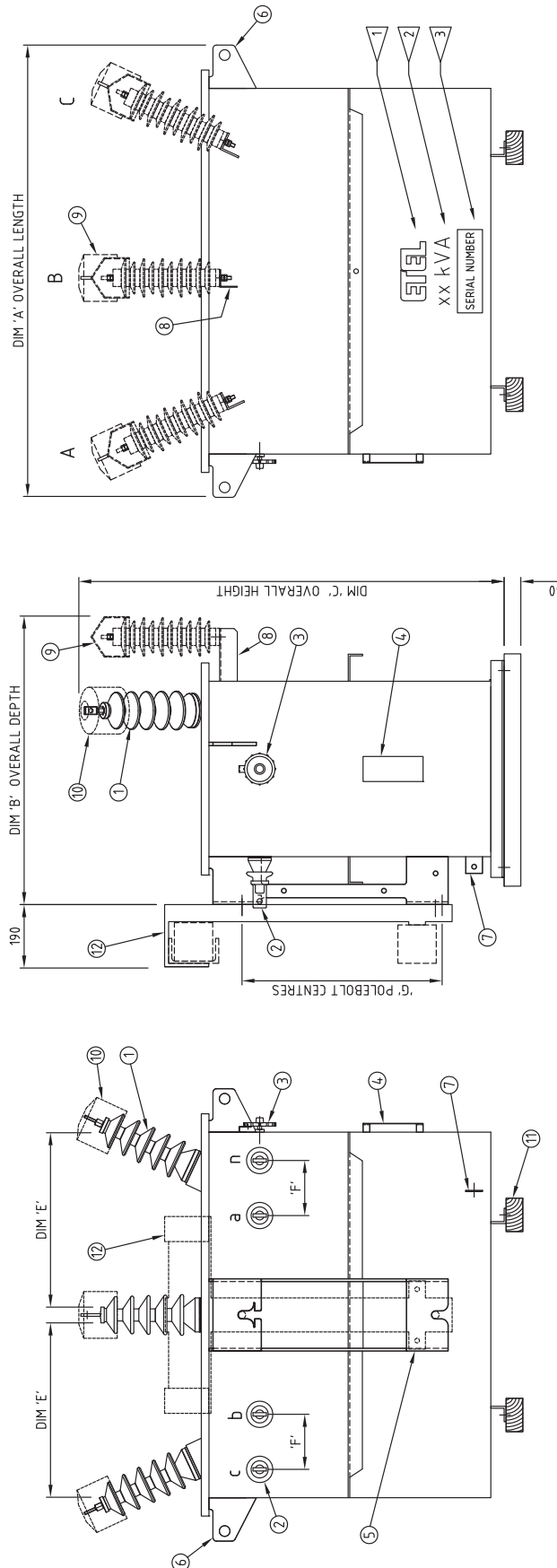

REV	DESCRIPTION	DRAWN	DATE	APPD.	DATE	DRAWN	DATE	A.ROBERTS
B	LV BUSHING DETAILS UPDATED	M.S.	20 MAR 12	P.L.				

 Distribution Transformers	
GENERAL ARRANGEMENT 25kVA & 63kVA 3Φ TRANSFORMER 22000 / 433 - 250 V	DRAWING No. 039,904.0551 REV B